

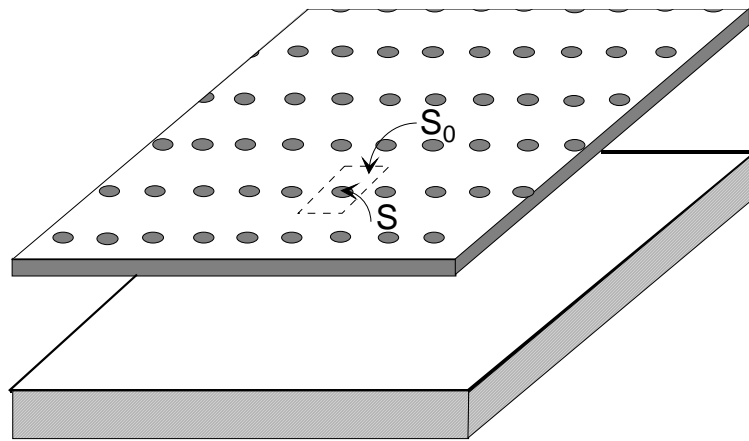

Absorbenter med mikroperforering; typer og anvendelser.

T.E. Vigran

Fordelt Helmholtzresonator



a)

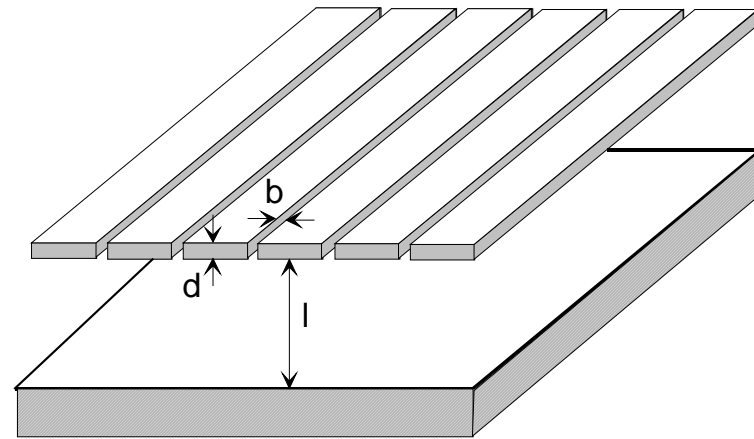

b)

Helmholtzresonator

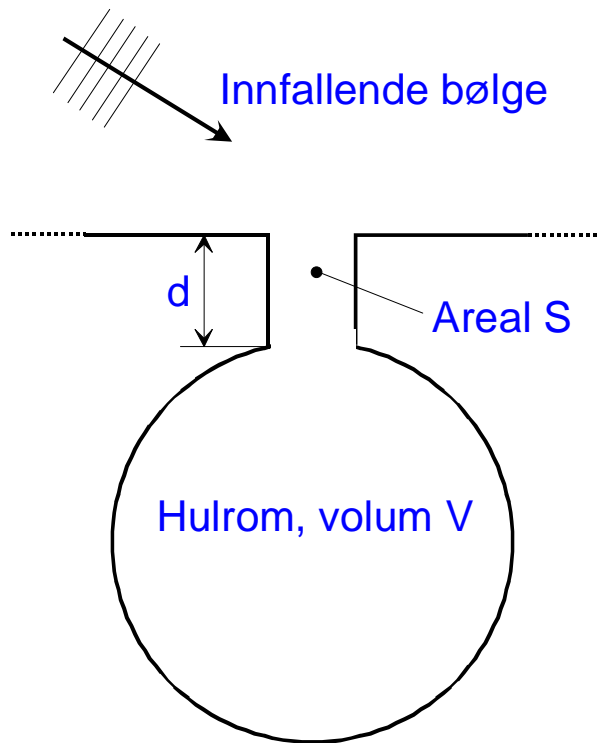

Hvordan beregne på en "mikrotrang" hals?

$$Z_{\text{ak}} = \frac{\Delta p}{\langle v_x \rangle S} = j \frac{\omega \rho_0 d}{\pi a^2} \left(1 - \frac{2}{s \sqrt{-j}} \frac{J_1(s \sqrt{-j})}{J_0(s \sqrt{-j})} \right)^{-1}$$

$$s = a \sqrt{\frac{\omega \rho_0}{\mu}} \quad \text{hvor } a \text{ er radius}$$

Mikrohull. Lavfrekvens tilnærmeelse

$$Z_{\text{ak}} \approx \frac{8\mu d}{\pi a^4} + j \frac{4}{3} \frac{\omega \rho_0 d}{\pi a^2}$$

Maa Dah-You (INTERNOISE 1984)
Presenterte meget gode tilnærmelser
for de generelle formlene.

WinFLAG, main window

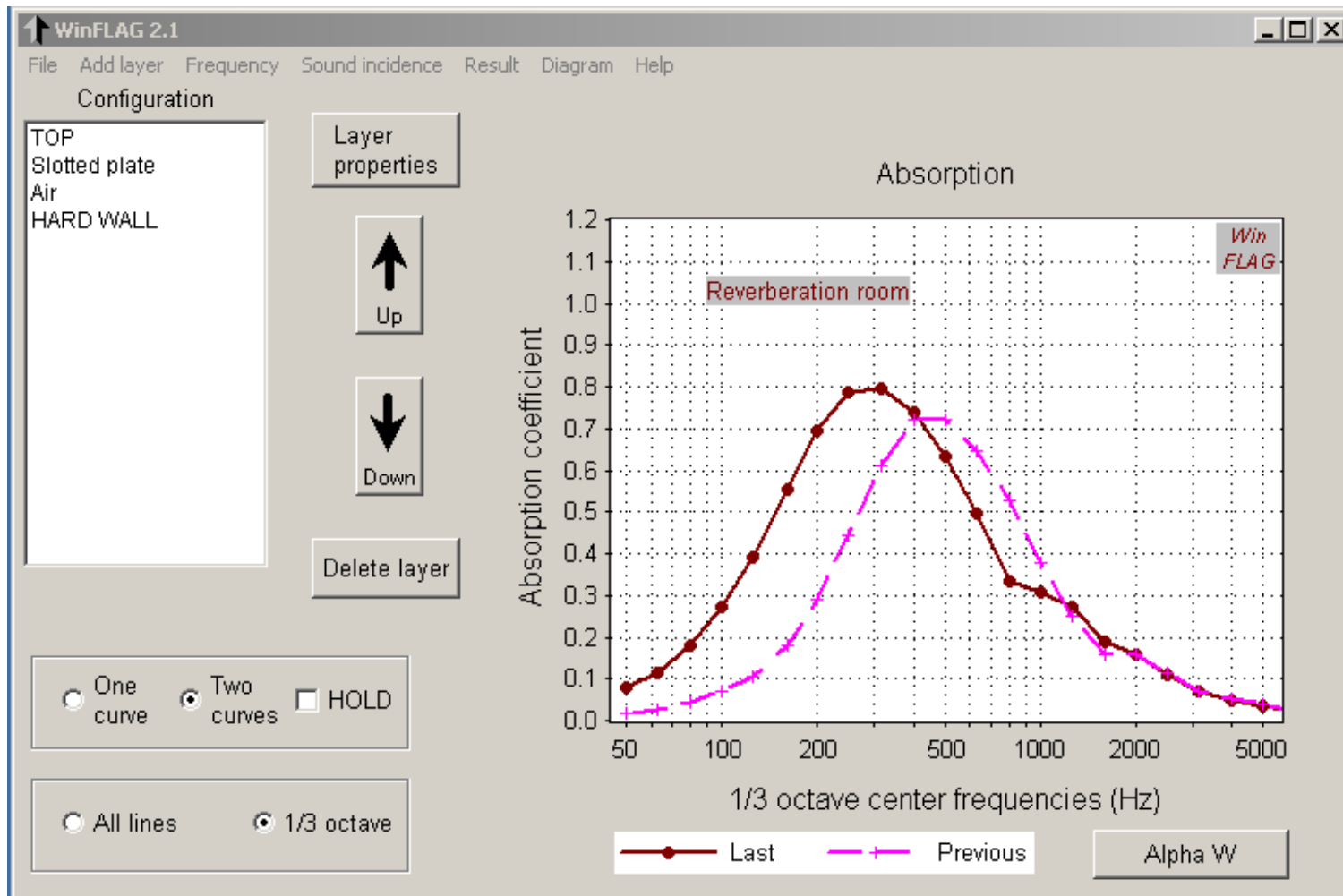

Mikroperforeert folie

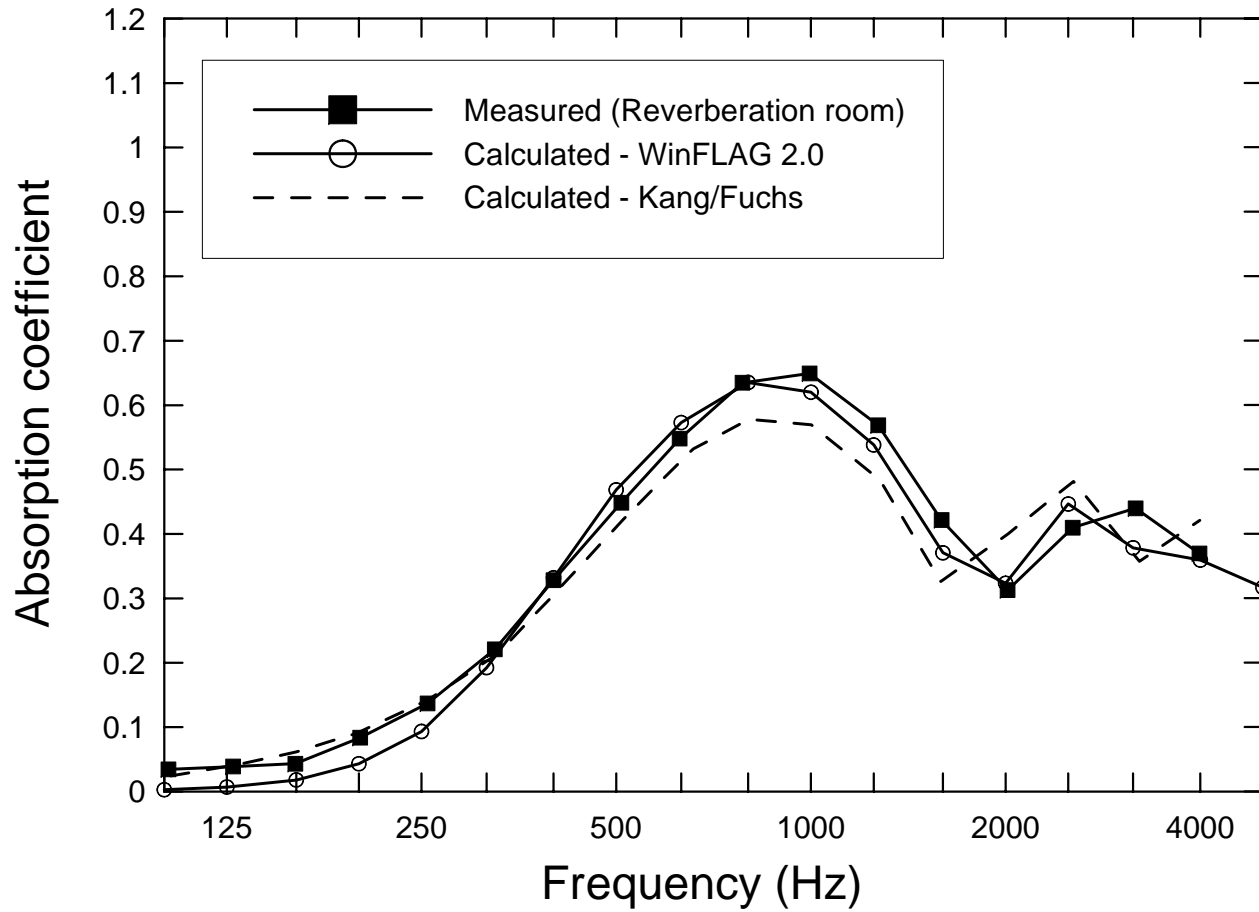

Slotted (slatted) panel

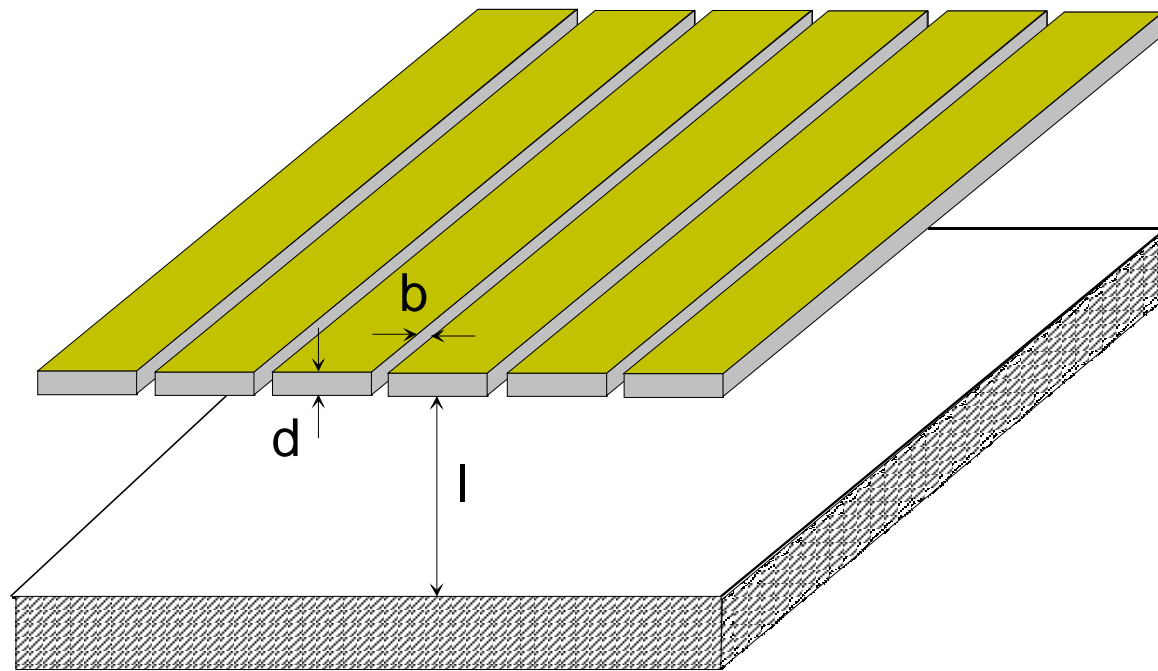

Laser-made slits

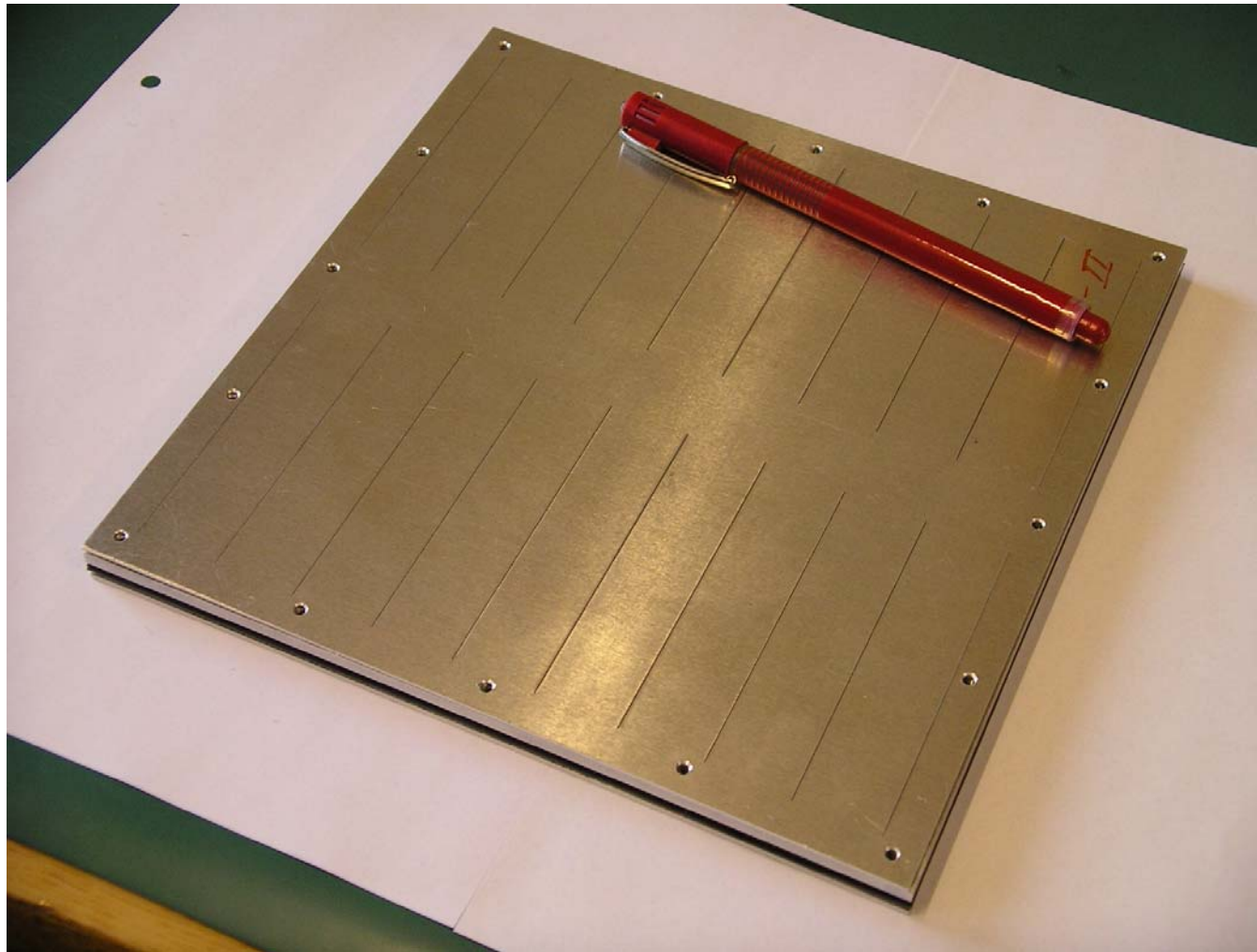

Theory

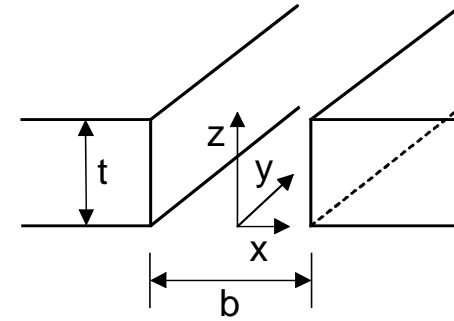

For an infinitely long slit:

$$Z' = j\rho\omega t = j \frac{\rho_0 \omega t}{1 - \frac{2}{\frac{k'b}{2}}} \quad \text{where} \quad k' = \sqrt{\frac{\omega\rho_0}{j\mu}}$$

Low frequency approximation:

$$Z' \approx \frac{12\mu t}{b^2} + \frac{1}{700} \frac{t b^2 \rho_0^2 \omega^2}{\mu} + j \frac{6}{5} \omega \rho_0 t$$

Measured and calculated results Standing wave tube

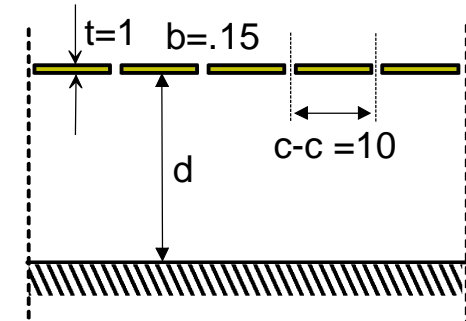
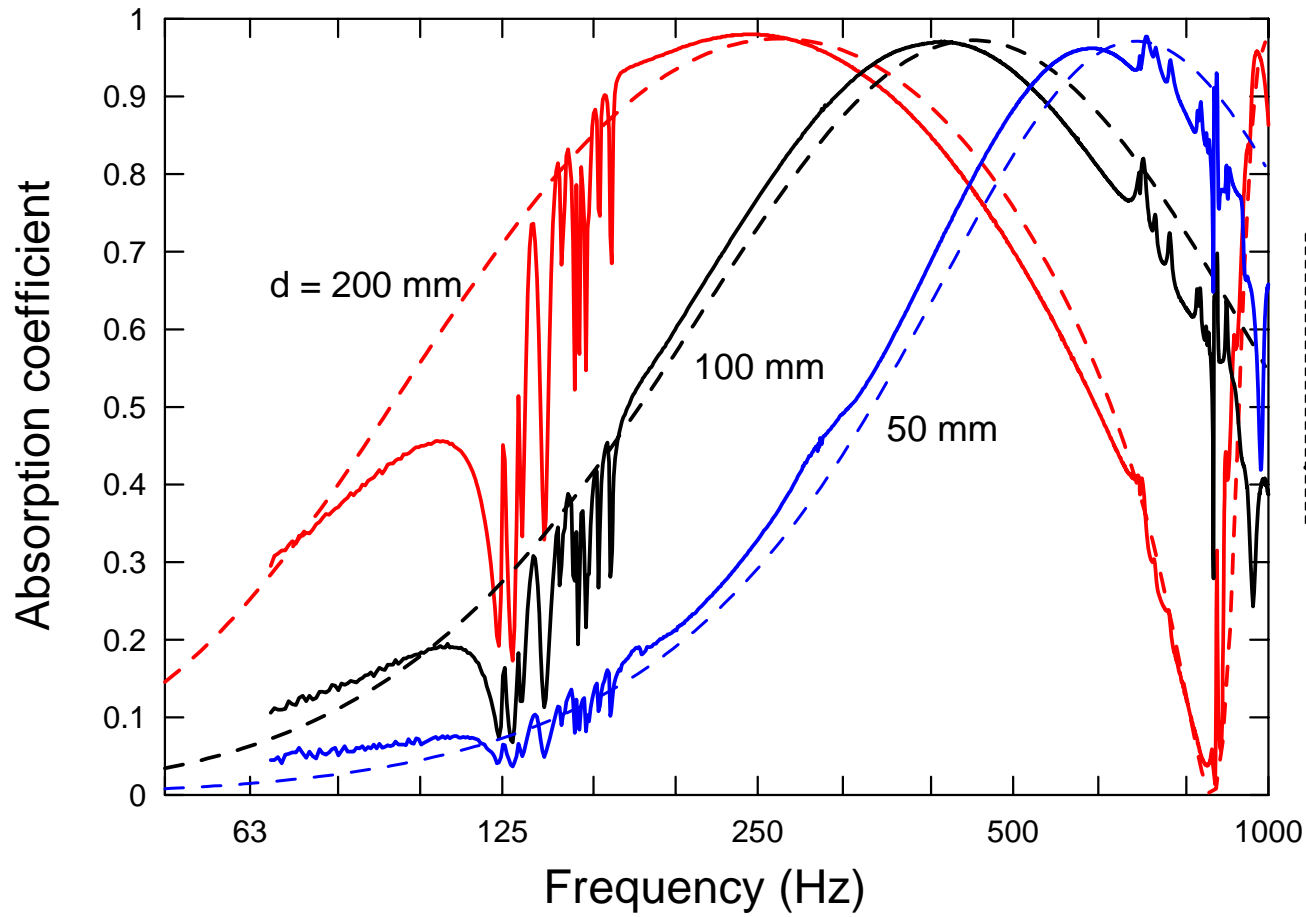

Reverberation room test

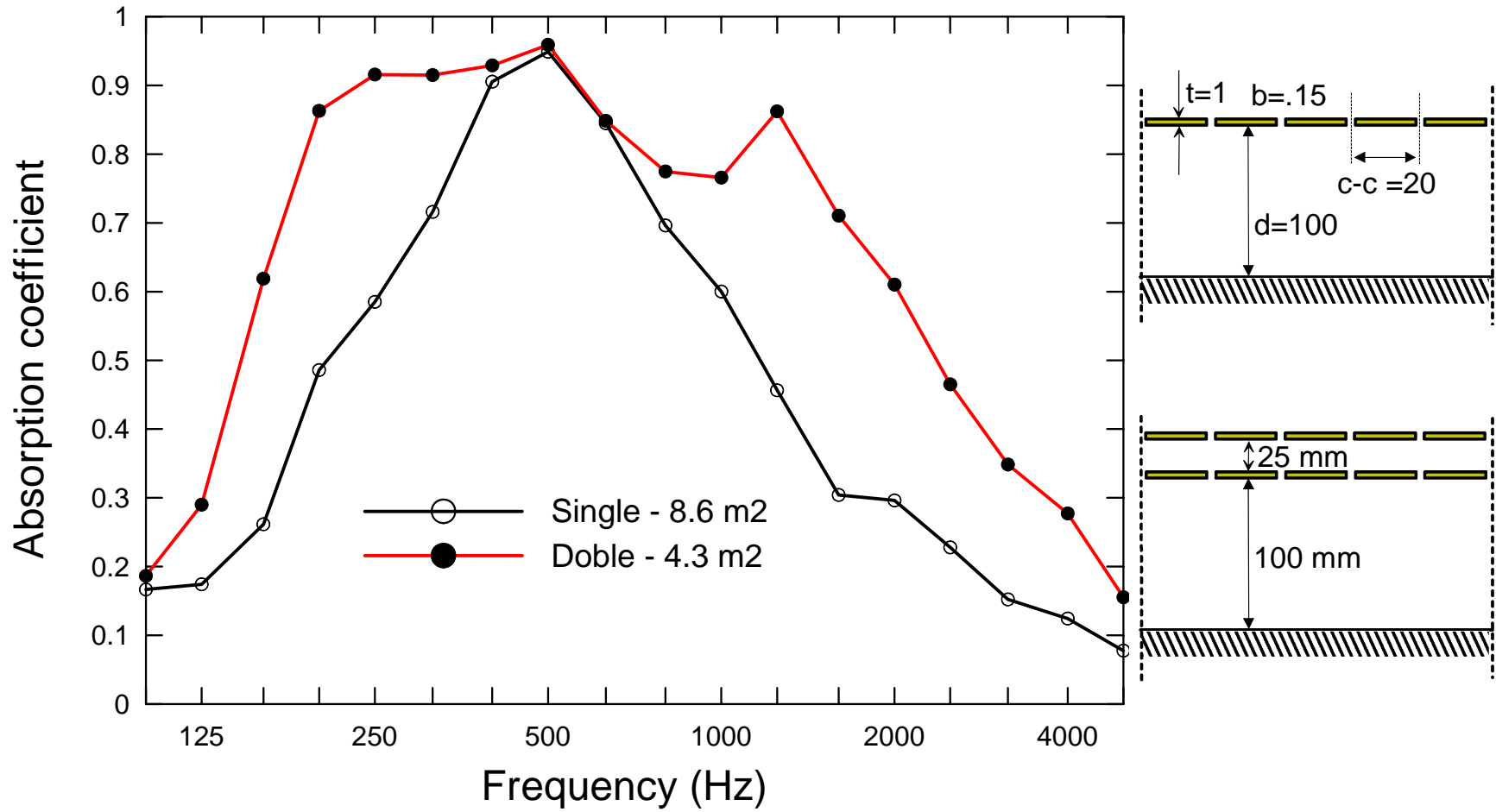



▶ [HOME PAGE](#)

▶ [PRODUCTS](#)

▶ [TECHNOLOGY](#)

▶ [PEOPLE](#)

▶ [COMPANY](#)

▶ [MEDIA](#)

▶ [NEWS & EVENTS](#)

▶ [CONTACT US](#)

A New Generation in Sound Absorption



DeAmp develops and markets fiber free acoustical ceilings and walls in hard materials. We offer the most affordable solution that covers all demands for customers with a desire for smart design, high acoustic quality and a healthier indoor environment.

[Read more >](#) | 27-05-2006

Latest News & Events

13-07-2006: **DeAmp Awarded Again**

DeAmp won first prize in the regional DnBNOR innovation contest on an event hosted b...



[Read more >](#)

[More News >](#)

29-05-2006: **Pilot Contract**

DeAmp has signed a pilot contract with Trondheim Kommune. DeAmp will deliver paneled ceil...



[Read more >](#)

Richard Birkelandsvei 2B
N-7491 Trondheim
Norway

Tel: (+47) 73 55 18 56
Fax: (+47) 73 55 18 70
E-mail: mail@deamp.com

Copyright © 2006 DeAmp AS.
All rights reserved.

Med kunstnerisk uttrykk



Konklusjon

Skal vi være på linje med Ke Liu et.al.?
(151st Meeting:Acoust.Soc.Am. 2006)

”This review shows that the MPA has potentials be be an ideal absorbing material in architectural acoustics in the 21st century”